



INSTALLATION INSTRUCTIONS FOR HI-TORQUE™ STARTER CHEVROLET

REMOVAL OF THE ORIGINAL STARTER

1. **CAUTION!** Before proceeding, the negative (-) or ground terminal must be removed from the battery. Failure to do so can result in damage to the vehicle and/or injury to the installer!
2. Remove the large cable from the starter motor. Label and remove the smaller wires that go to the solenoid.
3. Remove the two (2) mounting bolts holding the starter to the engine. If your vehicle has shims between mounting surface and the starter, keep these shims for possible re-use.

INSTALLATION OF THE HI-TORQUE STARTER MOTOR

1. Note that the starter mounting block has two pairs of mounting bolt holes. The first pair (refer to fig. A), are for mounting to an engine with the smaller Chevrolet ring gear (153 tooth). The second pair of holes are for mounting to an engine with the larger (168 tooth) ring gear.
2. Run a 3/8 X 16 (UNC) tap through the mounting bolt holes to clean out any grease or debris.
3. After determining the correct mounting bolt holes, temporarily attach the mounting block to the engine using the 3/8 X 4" bolts supplied. At this point DO NOT bolt the starter to the mounting block. Hold the starter motor temporarily up into position on the mounting block. While holding the starter motor in place, check for clearance between the starter and the engine block, and between the headers/exhaust system. NOTE: there are six pairs of mounting holes located at 20 degree increments. Rotate the starter until you have roughly equal clearance on both sides of the motor. Using a felt tipped marker, mark across the mounting block and the body of the starter motor. Remove the starter motor and the mounting block from the engine. Position the mounting block onto the starter motor. Install the two 5mm mounting screws into the pair of holes which allow the closest alignment of the previously made marks. Using either a 4mm or 5mm Allen wrench, temporarily tighten the two bolts.
4. End clearance between the ring gear and the pinion gear in the retracted position is critical (refer to figure B). Install the starter again and check the gap with a feeler gauge between the end of the pinion shaft and the back side of the ring gear. The clearance should be between .040" to .100". If the measurement is less than this, you will have to add a circular shim (supplied with the starter) between the starter motor and the mounting block. Each shim is .074" thick. If the distance is too great, remove a shim. If it is too small, add a shim. After determining the proper number of shims, tighten the bolts to 95 IN/LBS. We recommend that you use a 4mm or 5mm hex driver with an inch pound torque wrench to do this.
5. Correct gear backlash is of equal importance (refer to Figure C) Again, temporarily install the starter. Do not fully tighten the bolts at this time. Using a screwdriver or a pair of pliers, slide the pinion gear into engagement with the ring gear. Using a narrow feeler gauge, check the backlash between the pinion and ring gear teeth. Proper clearance should be .020" to .030" with .025" being ideal. If the clearance is less than .020" you will have to add a shim. Each of these shims are .015" thick. Add or remove shims to obtain the required backlash. NOTE: you will NOT have to remove the starter motor completely to replace these shims. You can do so by removing only one bolt and just loosening the other. The shims are slotted at one end, and can be slid into place with the starter still on the car. After the starter has been properly shimmed, it can be finally tightened. Torque to 25 FT/LBS using a 5/16 hex driver and a foot pound torque wrench.

ELECTRICAL CONNECTIONS

1. Using the pig tail connector supplied with the kit, splice into the wire that was used to "trigger" the solenoid. This should have been marked on disassembly. Refer to the manufacturer's wiring diagram if necessary. The pig tail can then be snapped into the black plastic receptacle on the side of the solenoid.
2. **NOTE:** In the event that your vehicle has been modified and is equipped with a remote solenoid, similar to that of a Ford, simply make a Jumper using the supplied "pig tail". Crimp an insulated ring terminal of the appropriate size onto the stripped end of the pig tail lead. Plug the pigtail connector into the black plastic receptacle on the side of the solenoid. The ring connector attaches to the B+ terminal of the starter.
3. Ensure there are no loose wires touching any "grounded" areas of the car. Also, ensure the wiring is not in a position that it could rub against the block, frame or exhaust system. Re-route if required.
4. Finally, the battery must be fully charged and properly grounded to the engine block or frame.
5. Reconnect the positive terminal on the battery and test for proper operation.

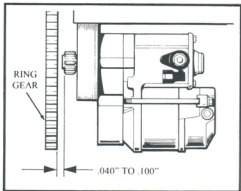

STARTER PINION TO RING GEAR CLEARANCE
FIGURE "B"

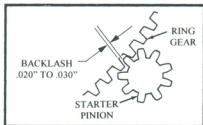

RING GEAR BACKLASH
FIGURE "C"

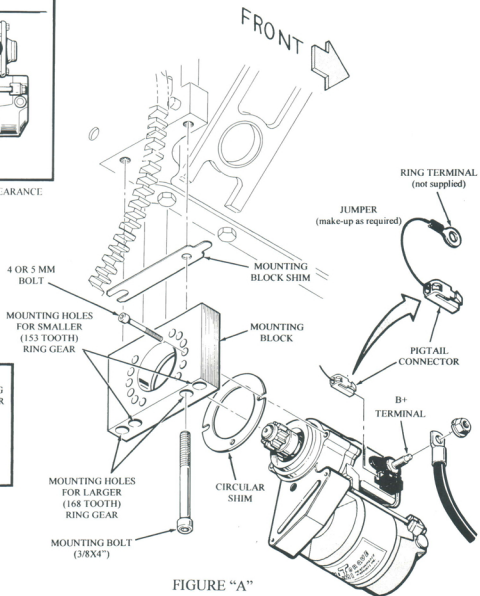

FIGURE "A"