

# CLEAR VIEW FILTRATION 6" HI-FLOW OIL OR FLUID FILTER DIRECTIONS

**MORE PRODUCTS & INFORMATION AT: [WWW.CLEARVIEWFILTRATION.COM](http://WWW.CLEARVIEWFILTRATION.COM) OR [WWW.BILLETCONNECTION.COM](http://WWW.BILLETCONNECTION.COM)**

CLEAR VIEW FILTRATION'S NEW PATENT PENDING SEE THROUGH FLUID FILTER ASSEMBLY ALLOWS THE USER TO VISUALLY SEE THE FLUID PUMPING THROUGH THE FILTER, WHICH HELPS IN DETERMINING THE CONDITION OF THE FLUID. WHEN FLUID IS NOT BEING PUMPED THROUGH THE FILTER, THIS FILTER ASSEMBLY CAN BE QUICKLY DRAINED USING COMPRESSED AIR, EXPOSING THE FILTER ELEMENT AND THE PARTICLES FILTERED OUT OF THE OIL SYSTEM. EVEN WHEN FILTERING NON TRANSPARENT FLUID LIKE ENGINE OIL. THIS ALLOWS THE USER TO VISUALLY INSPECT THE CONTAMINANTS AND PARTICLES FILTERED OUT OF THE OIL SYSTEM, SO THE USER CAN DETERMINE IF THE CONTAMINANTS AND PARTICLES ARE FROM NORMAL USE OR IF THE CONTAMINANTS AND PARTICLES ARE FROM PARTS EXCESSIVELY WEARING IN MACHINERY OR IN THE ENGINE SUPPLYING THE FILTER ASSEMBLY. THIS CAN BE DONE IN SECONDS AFTER THE SUPPLY OF FLUID IS TURNED OFF. THE USER CAN CHECK THE FILTER ELEMENT WITHOUT DRAINING OR LEAKING ANY FLUID OR OIL, UNBOLTING OR LOOSENING ANY FASTENERS OR FITTINGS AND WITHOUT THE LOSS OF FLUID OR OIL OUT OF THE SYSTEM .

**SEE THROUGH OIL FILTERS ARE RATED FOR 150 PSI MAXIMUM PRESSURE AT A MAX FAHRENHEIT TEMP OF 200 DEGREES**

## 6" HI-FLOW FILTER ASSEMBLY PART #100-60 AND #100-115

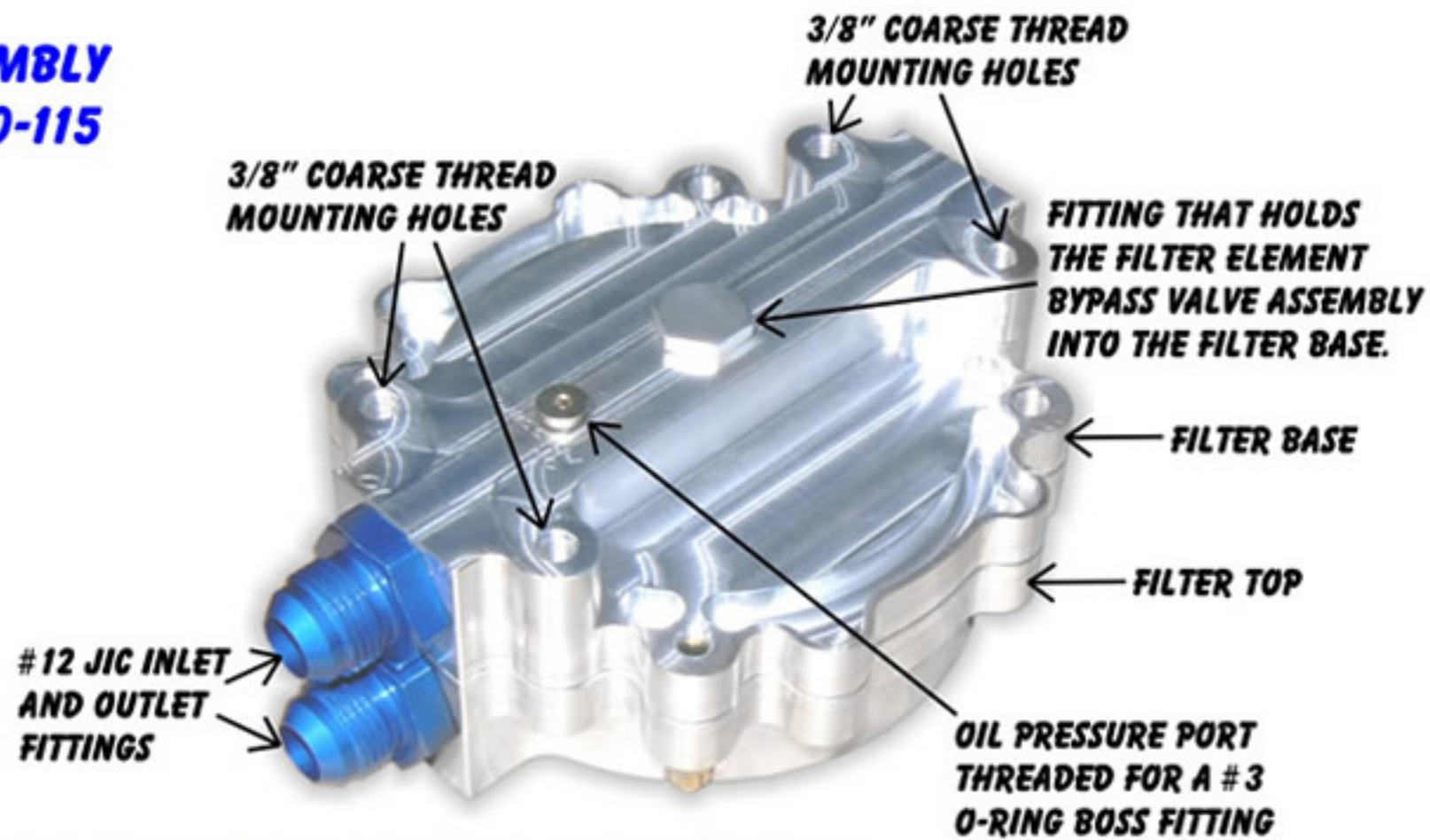

#12 JIC FITTINGS COME IN EITHER BLUE ANODIZED ALUMINUM OR GALVANIZED STEEL

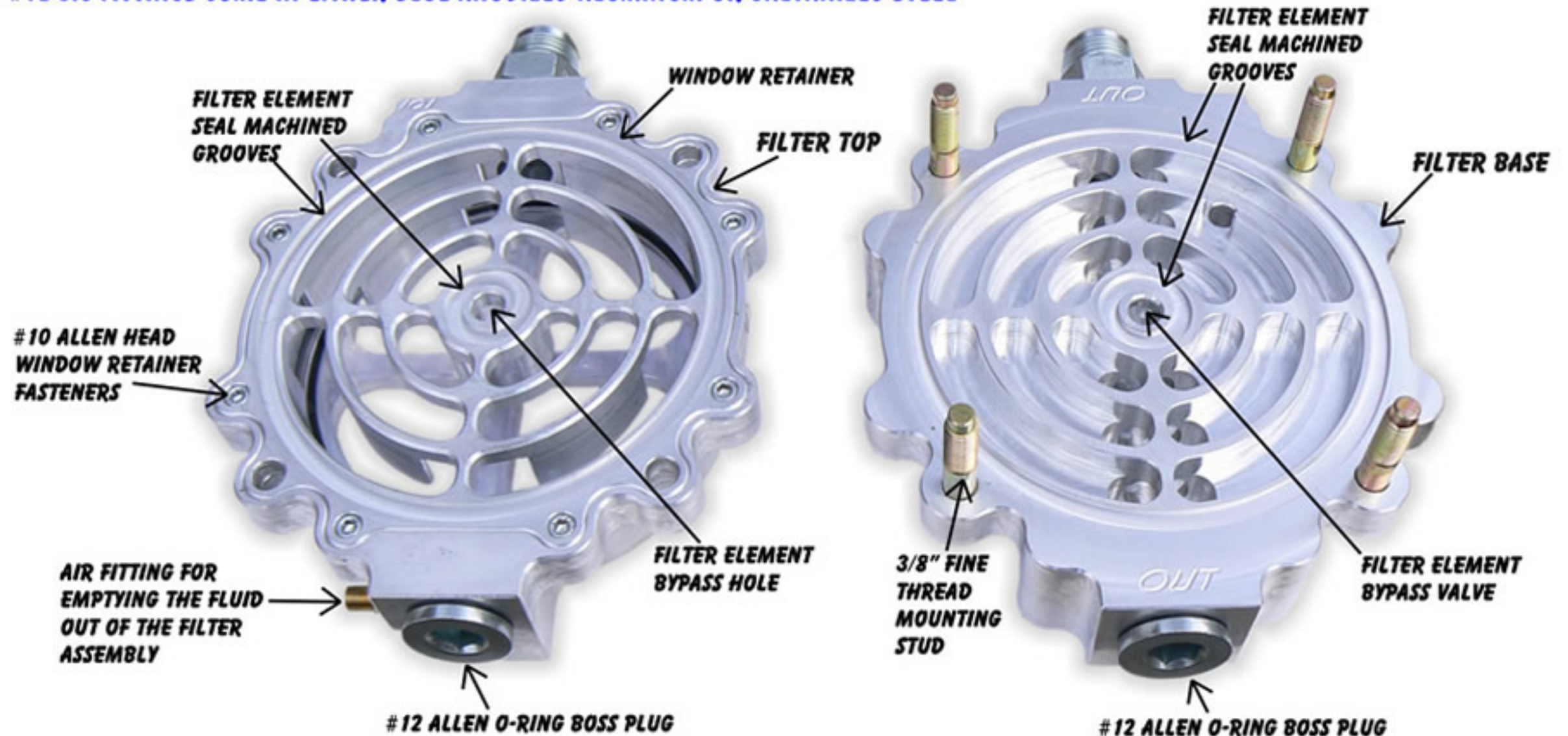

## CLEAR VIEW FILTRATION'S GUARANTEE (IMPORTANT!! READ BEFORE INSTALLING)

THIS OIL FILTER IS GUARANTEED FOR ONE YEAR FROM DATE OF PURCHASE TO BE FREE FROM DEFECTS IN MATERIALS AND WORKMANSHIP. WE SHALL IN NO EVENT BE LIABLE FOR DEATH, INJURIES, OR DAMAGES TO PERSONS OR PROPERTY ARISING FROM THE USE OF THIS PRODUCT. THIS INCLUDES DOWN TIME, LOSS OF USE OF THE PRODUCT, MACHINERY, OR VEHICLE. ALSO TOWING, RENTING OR BUYING A VEHICLE DURING DOWN TIME. IF THERE IS EVER A PROBLEM WITH THE FILTER ASSEMBLY, THE FILTER MUST BE SENT BACK TO CLEAR VIEW FILTRATION FOR ALL WARRANTIES OR GUARANTEE IS VOID. WE SHALL NOT BE LIABLE FOR SHIPPING COSTS OF THE FILTER ASSEMBLY, OR LABOR COSTS TO UNHOOK OR REINSTALL THE FILTER ASSEMBLY. IF THE FILTER ASSEMBLY IS INSTALLED THE PURCHASER AND OR USER OF THE PRODUCT IS AGREEING TO THE TERMS ABOVE. IF THE PURCHASER AND OR USER OF THE PRODUCT DOES NOT AGREE TO THE TERMS ABOVE, AND THE FILTER ASSEMBLY WAS NOT DAMAGED, SCRATCHED, OR INSTALLED. THEN CONTACT US AT CLEAR VIEW FILTRATION AND SEND THE FILTER ASSEMBLY BACK AND WE WILL GIVE THE PURCHASER A FULL REFUND.

# 6" HI-FLOW FILTER DIRECTIONS **READ BEFORE INSTALLING**

PAGE # 2 OF 2

**THE FILTER ASSEMBLY NEEDS BE MOUNTED FLAT SO THE SIGHT WINDOW IS FACING UP AND BE MOUNTED SO THE INLET AND OUTLET HOSES ARE LEVEL OR GOING UP TO THE FILTER ASSEMBLY. IF THE HOSES ARE GOING DOWN TO THE FILTER ASSEMBLY, AFTER DRAINING THE FILTER ASSEMBLY, THE OIL OR FLUID WILL RUN BACK INTO THE FILTER ASSEMBLY COVERING UP THE FILTER ELEMENT.**

**THE FILTER ASSEMBLY SHOULD BE MOUNTED USING AT LEAST TWO OF THE 3/8" COARSE THREADED MOUNTING HOLES IN THE BOTTOM OF THE FILTER BASE. WE ALSO HAVE DIFFERENT MOUNTING BRACKET KITS AVAILABLE, WHICH MOUNTS THE FILTER ASSEMBLY FOR ALL DIFFERENT APPLICATIONS. CHECK OUR WEB SITE FOR MORE BRACKET KIT OPTIONS AND MORE PRODUCT INFORMATION.**

**THE FILTER ASSEMBLY HAS OUTLET AND INLET THREADED OPENINGS AT EITHER END OF THE FILTER ASSEMBLY. IF ONLY ONE INLET OR OUTLET IS BEING USED THE OTHER END NEEDS TO BE PLUGGED. BOTH INLETS AND OUTLETS CAN BE USED WHICH WILL DOUBLE THE VOLUME OF FLUID THAT WILL FLOW THROUGH THE FILTER ASSEMBLY. FLUID WILL ONLY FLOW AS MUCH AS THE SMALLEST ORIFICE IN A FLUID SYSTEM. FOR EXAMPLE THE OUTLET ORIFICE ON A BIG BLOCK CHEVY IS 5/8" OR .625" DIAMETER HOLE. ONE INLET OPENING ON THE FILTER ASSEMBLY HAS A LARGER THAN 5/8" OR .625" DIAMETER AREA OPENING, SO ONLY ONE #12 INLET AND OUTLET OPENING NEED TO BE USED. IF THE FILTERING APPLICATION WAS A LARGE INDUSTRIAL ENGINE THAT HAS A 3/4" OR .750" DIAMETER OR LARGER OPENING THAN BOTH INLET AND OUTLET OPENINGS SHOULD BE USED. MOST APPLICATIONS ONLY NEED ONE INLET AND OUTLET OPENING. A #16 FITTING WITH A .750" HOLE COULD BE USED IF ONLY ONE INLET AND OUTLET OPENING IS USED.**

**THE THREADED INLET AND OUTLET OPENINGS ARE THREADED TO 1 1/16" 12 THREADS PER INCH. THIS THREAD IS ALSO CALLED #12 STRAIGHT THREAD. THE FITTINGS USED IS CALLED A #12 STRAIGHT THREAD WITH O-RING OR A #12 O-RING BOSS FITTING THAT THREADS INTO THE FILTER, AND THE OTHER END COMES IN MANY DIFFERENT FITTING TYPES TO MAKE IT EASY TO HOOK UP TO DIFFERENT APPLICATIONS AND FLUID SYSTEMS. MOST APPLICATIONS USE A #12 O-RING BOSS ON ONE END AND A #12 JIC MALE ON THE HOSE END OF THE FITTING. THE NUT OF THE FITTING MUST BE 1 1/4" SOME ALUMINUM FITTINGS HAVE 1 3/8" NUT WHICH CAN HIT EACH OTHER IF BOTH INLET AND OUTLET OPENINGS ARE AT THE SAME END. THE #12 FITTINGS COME IN MANY DIFFERENT STYLES AND COME IN STEEL AND ALUMINUM, CHECK OUT OUR WEBSITE FOR MORE FITTING AND PRODUCT INFO.**

**WE OFFER BLOCK ADAPTERS FOR HOOKING THE FILTER ASSEMBLY TO DIFFERENT ENGINES. THEY ARE A HIGH FLOW DESIGN THAT WILL NOT RESTRICT ANY OIL FLOW. THE BLOCK ADAPTERS HAVE THE SAME THREAD AND USE THE SAME INLET AND OUTLET FITTINGS THAT THE FILTER ASSEMBLY DOES. THIS INSURES THE BLOCK ADAPTER, FITTINGS, HOSES, AND FILTER ASSEMBLY WILL FLOW MORE OIL THAN EVEN A ALL OUT RACE ENGINE CAN PUMP, WITHOUT RESTRICTION!**

**THE FILTER ASSEMBLIES FILTER ELEMENT IS STAINLESS STEEL MESH WITH A VITON RUBBER SEAL AROUND THE INSIDE AND THE OUTSIDE OF THE FILTER ELEMENT. VITON RUBBER IS HEAT AND CHEMICAL RESISTANCE, AND ALSO ALCOHOL RESISTANT WHEN USING ALCOHOL FOR FUEL. THESE SEALS FIT IN GROOVES MACHINED INTO THE FILTER BASE AND TOP ASSEMBLY. THE FILTER ELEMENT CAN BE PUT IN WITH EITHER SIDE FACING UP OR DOWN. MAKE SURE THE FILTER ELEMENT SEALS ARE IN THE MACHINED GROOVES IN THE FILTER ASSEMBLY, OR IT COULD DAMAGE THE VITON RUBBER SEALS ON THE FILTER ELEMENT. AFTER THE FILTER ELEMENT IS SET ON THE FILTER BASE WITH THE SEALS IN THE MACHINED GROOVES, THE TOP OF THE FILTER ASSEMBLY CAN BE PUT ON. THE FOUR 3/8" STUDS IN THE FILTER BASE WILL ALIGN THE TOP HOUSING SO THE FILTER ELEMENT SEALS WILL LINE UP WITH THE MACHINED GROOVES IN THE TOP HOUSING. INSTALL THE TOP HOUSING AND BOLT TOGETHER USING THE FOUR 3/8" AN FLAT WASHERS, AND THE 3/8" FINE THREAD 12 POINT NUTS AND TIGHTEN ALL FOUR NUTS GRADUALLY. DO NOT TIGHTEN ONE NUT ALL THE WAY, MAKE SURE TO TIGHTEN ALL FOUR A LITTLE AT A TIME THAN SNUG ALL 4 NUTS, **DO NOT OVER TIGHTEN IT COULD DAMAGE THE FILTER ELEMENT SEALS.****

**THESE FOUR NUTS ARE THE ONLY FASTENERS THAT NEED TO BE TAKEN OFF TO CLEAN OR CHANGE THE FILTER ELEMENT. THE FILTER TOP ASSEMBLY HAS THREE VITON RUBBER O-RINGS, WHICH SEAL THE VIEWING WINDOW AND WINDOW RETAINER INTO THE FILTERS TOP HOUSING. THESE CAN BE CHANGED EASILY BY TAKING OUT THE EIGHT #10 - 24 THREADS PER INCH ALLEN HEAD FASTENERS, THESE ARE PUT IN WITH BLUE LOC TIGHT. WHEN THE EIGHT FASTENERS ARE OUT, THE WINDOW RETAINER AND THE VIEWING WINDOW WILL COME OUT. THE O-RING ON THE WINDOW RETAINER IS A 161 VITON, THE O-RING IN THE VIEWING WINDOW IS A 159 VITON, AND THE O-RING IN THE TOP HOUSING WHICH SEALS AROUND THE WINDOW IS A 162 VITON. THESE ARE COMMON O-RINGS THAT CAN BE PURCHASED AT YOUR LOCAL O-RING STORE OR PURCHASED THROUGH CLEAR VIEW FILTRATION.COM. AFTER REPLACING THE THREE O-RINGS PUT A LITTLE OIL ON THEM AND HOLD THE TOP HOUSING LIKE IT GOES ON THE FILTER WITH THE TOP SIDE FACING UP. NOW INSTALL THE WINDOW FROM THE BOTTOM WITH THE O-RING IN THE GROOVE OF THE WINDOW FACING UP. IT WILL TAKE A LITTLE FORCE TO PUSH THE WINDOW IN. THEN INSTALL THE WINDOW RETAINER WITH THE O-RING IN THE GROOVE FACING UP. THIS WILL ENSURE THE O-RINGS WILL STAY IN THEIR O-RING GROOVES. NOW HOLD THE TOP ASSEMBLY TOGETHER AND FLIP IT OVER AND INSTALL THE EIGHT ALLEN HEAD FASTENERS. USE A LITTLE BLUE LOC TIGHT AND HAND TIGHTEN. THESE ARE SMALL FASTENERS, DO NOT OVER TIGHTEN, OR IT COULD STRIP OUT THE THREADS. IF THIS HAPPENS YOU MUST PUT A HELI-COIL OR FIX THE THREADS IN THE FILTER TOP. THERE IS A LOT OF FORCE APPLIED TO THESE FASTENERS AND THE FILTER MUST HAVE THEM ALL TIGHT AND WITH GOOD THREADS. THIS IS IMPORTANT.**

**THE FILTER ASSEMBLIES ARE PACKAGED WITH THE FOUR 12 POINT MOUNTING NUTS LOOSE SO MAKE SURE TO TIGHTEN! WHEN THE FILTER ASSEMBLY IS MOUNTED AND EVERY THING IS TIGHT, YOU CAN START THE ENGINE. LOOK FOR LEAKS INCASE ANYTHING WAS LEFT LOOSE. WHEN THE MOTOR IS NOT RUNNING, THE FILTER ASSEMBLY CAN BE EMPTIED OF OIL OR FLUID BY SIMPLY USING COMPRESSED AIR WITH AN AIR CHUCK FOR FILLING TIRES TO APPLY A LITTLE AIR PRESSURE TO THE AIR FITTING ON THE SIDE OF THE INLET OPENING. IT JUST NEEDS A LITTLE SHOT OF AIR THERE IS NO NEED TO HOLD AIR PRESSURE STEADY ON THE AIR FITTING. IF THE FILTER DOES NOT EMPTY COMPLETELY ON THE FIRST SHOT OF AIR JUST GIVE IT A SECOND IF NEEDED. IT WILL ONLY TAKE A FEW SECONDS TO EMPTY, AND ALLOW VISUAL INSPECTION OF THE FILTER ELEMENT. THIS WILL ALSO MAKE IT POSSIBLE TO TAKE THE FILTER ASSEMBLY APART TO CLEAN THE FILTER ELEMENT WITHOUT LEAKING OIL ALL OVER.**

**VERY IMPORTANT! THE CLEAR WINDOW IS POLY CARBONATE, IT HAS A COATING THAT IS CHEMICAL AND SCRATCH RESISTANT. IT WILL SCRATCH IF SCOTCH BRITE, SAND PAPER OR COARSE CLOTH IS USED. TO CLEAN THE VIEWING WINDOW. USE A SOFT CLOTH WITH WINDEX GLASS CLEANER WHEN CLEANING THE WINDOW. REPLACEMENT WINDOWS ARE AVAILABLE IF DAMAGED.**

**THE FILTER ELEMENT SEALS WILL WEAR OUT OVER TIME CREATING LEAKS. WE RECOMMEND HAVING A SPARE FILTER ELEMENT!**